



Encasa

16 Fibre Distribution Point



ENCASA 16 FIBRE DISTRIBUTION POINT



PRODUCT OVERVIEW

The Encasa range of fibre distribution points have been designed to fit within the FTTx network. These enclosures can be aerial, or wall mounted. Made from 100% virgin UL94-V0 rated material, UV stable and are IP56 rated, allowing them to be used in both internal and external applications.

This Encasa fibre distribution point accommodates 16 fibres (using LC connections) or 8 fibres (using SC connections). Flexibility is increased through the option to use the enclosure for traditional splicing of cables with a capacity of 24 fibres and the installation of pre-terminated cables via the split gland cable exit points that accept both flat and round cable.

The use of splitters is also possible with mounting positions for up to 4 units found on the underside of the adaptor tray.

Blown fibre installations can also be accommodated, with a dedicated gas seal holder housed within the cable storage area in the base of the enclosure.

Each enclosure comes pre-loaded with APC adaptors and splitters. The splitters are terminated with APC connections on the outgoing end and unterminated on the incoming end as standard. Options are available to have adaptors and standard pigtails or loaded with adaptors only.

The cable entry points allow for midspan cable installation and for cable to be passed through to feed further enclosures in the network.

Integrated fibre management allows 250µm and 900µm fibre to be installed, keeping the fibres safe and always maintaining the required bend radius.

PRODUCT FEATURES



Adaptor Field



Cable Tie Points

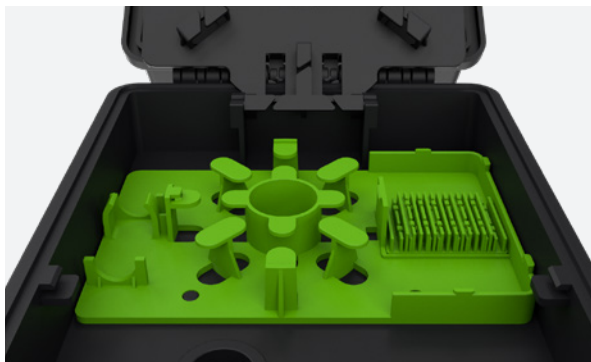

Gas Seal Holder, Fibre Storage and Splice Area



Splitter Area

GENERAL

Maximum number of fibres	8 SC or 16 LC
Maximum number of splices	24
Adaptor type	SC Duplex/LC Quad
Maximum number of adaptor positions	4
IP rating	IP56 - suitable for internal and external installations
UV stable	Yes
Material	ABS+PC
UL94-V0	Yes
Colour	Light grey (RAL 7035) or black (RAL 9005) Other colours available subject to MOQ
Dimensions (mm)	193mm H x 155mm W x 77mm D

SPLITTER OPTIONS

1:4 plc splitter	Maximum of 4
1:8 plc splitter	Maximum of 2
1:16 plc splitter	Maximum of 1

CABLE ENTRY AND EXIT PARAMETERS

Number of feeder cable entry points	2
Midspan capability	Yes
Cable diameter	6mm – 12mm
Number of drop cable exit points	16
Cable diameter	3mm – 6mm
Number of rear cable entry points	1
Cable diameter	6mm – 12mm



Cable Entry Points



Cable Exit Points

LC AND SC APC ADAPTOR SPECIFICATION

Insertion loss	< 0.2 dB
Durability (500 mating)	< 0.2 dB max increase
Operating temperature	-40°C to 80°C
Retention force	200 - 600 grams
Alignment sleeve material	Ceramic
Flammability rated	UL94-V0
Polish type	APC

SPLITTER SPECIFICATION

	1x4	1x8	1x16
Operating wavelength	1260 to 1650 nm		
Fibre type	G657A2		
Temperature stability (dB) at -40°C to 85°C	≤0.4	≤0.4	≤0.5
Storage temperature	-40°C to 85°C		
Return loss	≥55dB		

DIMENSIONS

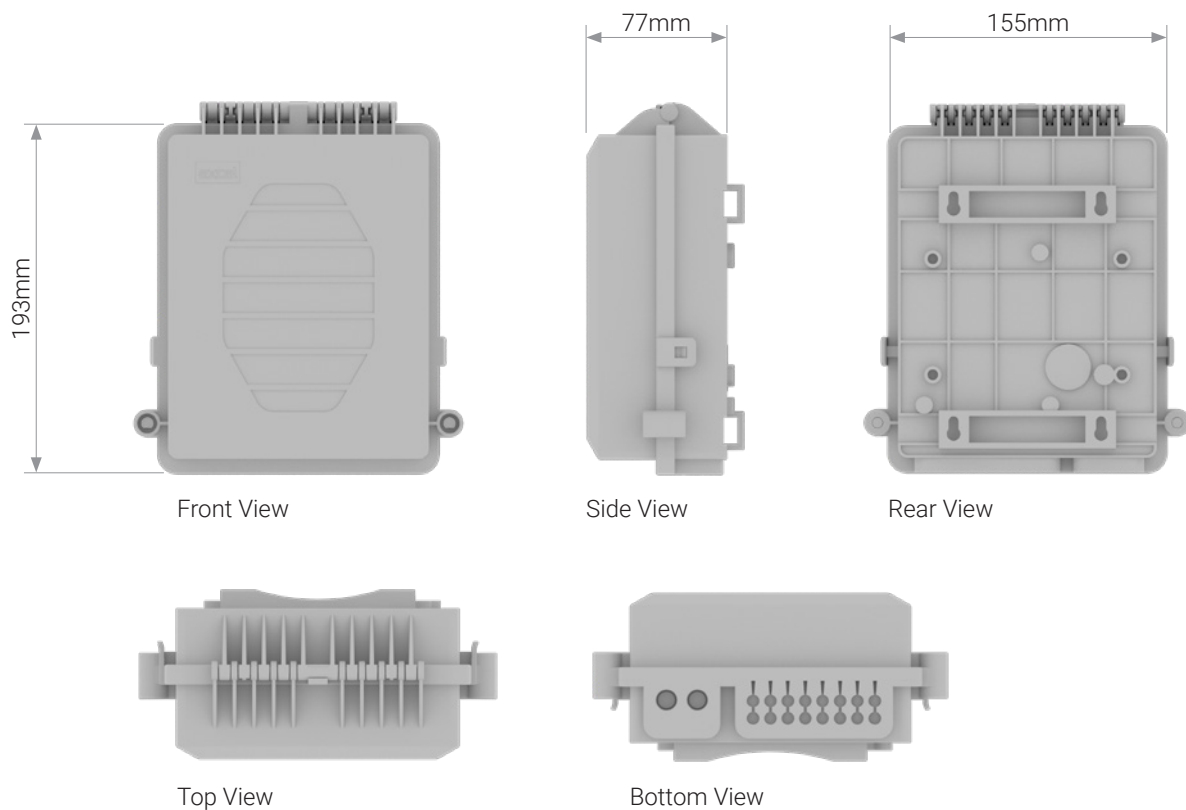

PART NUMBER INFORMATION

Part Number	Product Description
916-000	Encasa 16 fibre distribution point loaded with 16 x LCA adaptors + 4 x 1:4 splitters black
916-001	Encasa 16 fibre distribution point loaded with 16 x LCA adaptors + 4 x 1:4 splitters grey
916-002	Encasa 16 fibre distribution point loaded with 16 x LCA adaptors + 2 x 1:8 splitters black
916-003	Encasa 16 fibre distribution point loaded with 16 x LCA adaptors + 2 x 1:8 splitters grey
916-004	Encasa 16 fibre distribution point loaded with 16 x LCA adaptors + 1 x 1:16 splitter black
916-005	Encasa 16 fibre distribution point loaded with 16 x LCA adaptors + 1 x 1:16 splitter grey
916-006	Encasa 16 fibre distribution point loaded with 8 x SCA adaptors + 1 x 1:8 splitter black
916-007	Encasa 16 fibre distribution point loaded with 8 x SCA adaptors + 1 x 1:8 splitter grey
916-008	Encasa 16 fibre distribution point loaded with 8 x SCA adaptors + 2 x 1:4 splitters black
916-009	Encasa 16 fibre distribution point loaded with 8 x SCA adaptors + 2 x 1:4 splitters grey

Design registration and patent pending.



Excel House, Junction Six Industrial Park
Electric Avenue, Birmingham, B6 7JJ

Phone: 0800 75 75 65
Email: FTTx@mayflex.com

www.excel-networking.com

ENCASA PRODUCT RANGE

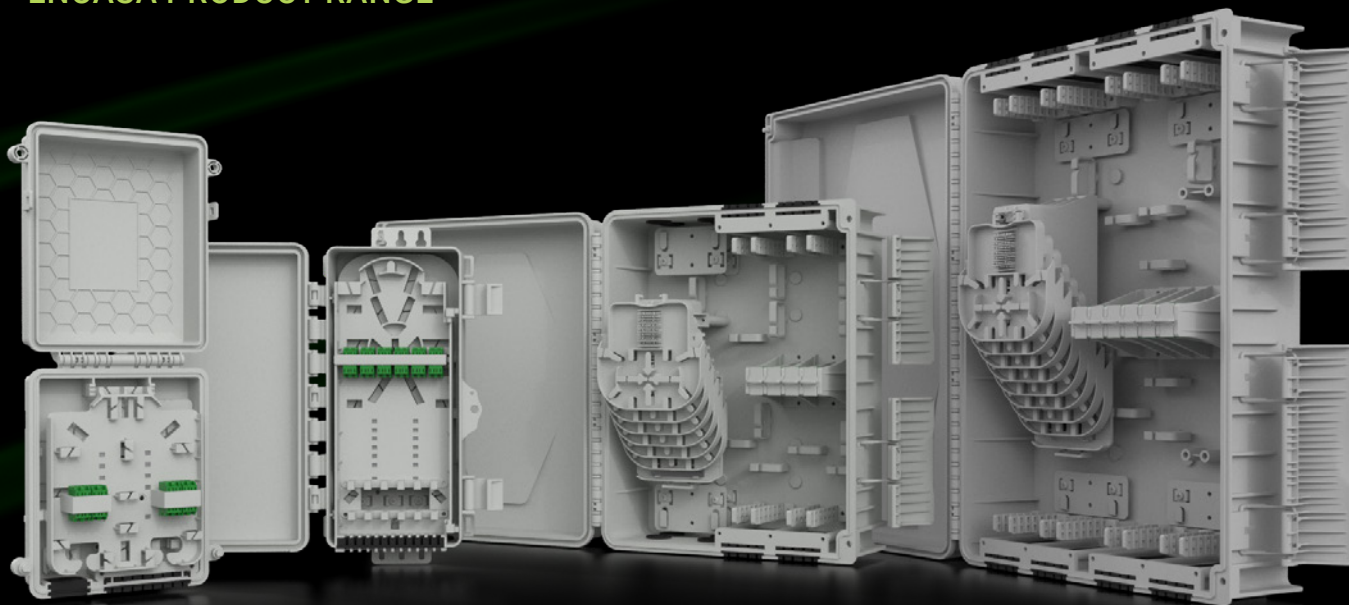

The Encasa range from Excel provides flexible, easy to use enclosures with a range of connection options and capacities, complemented by fast to install pre-connectorised cables.