

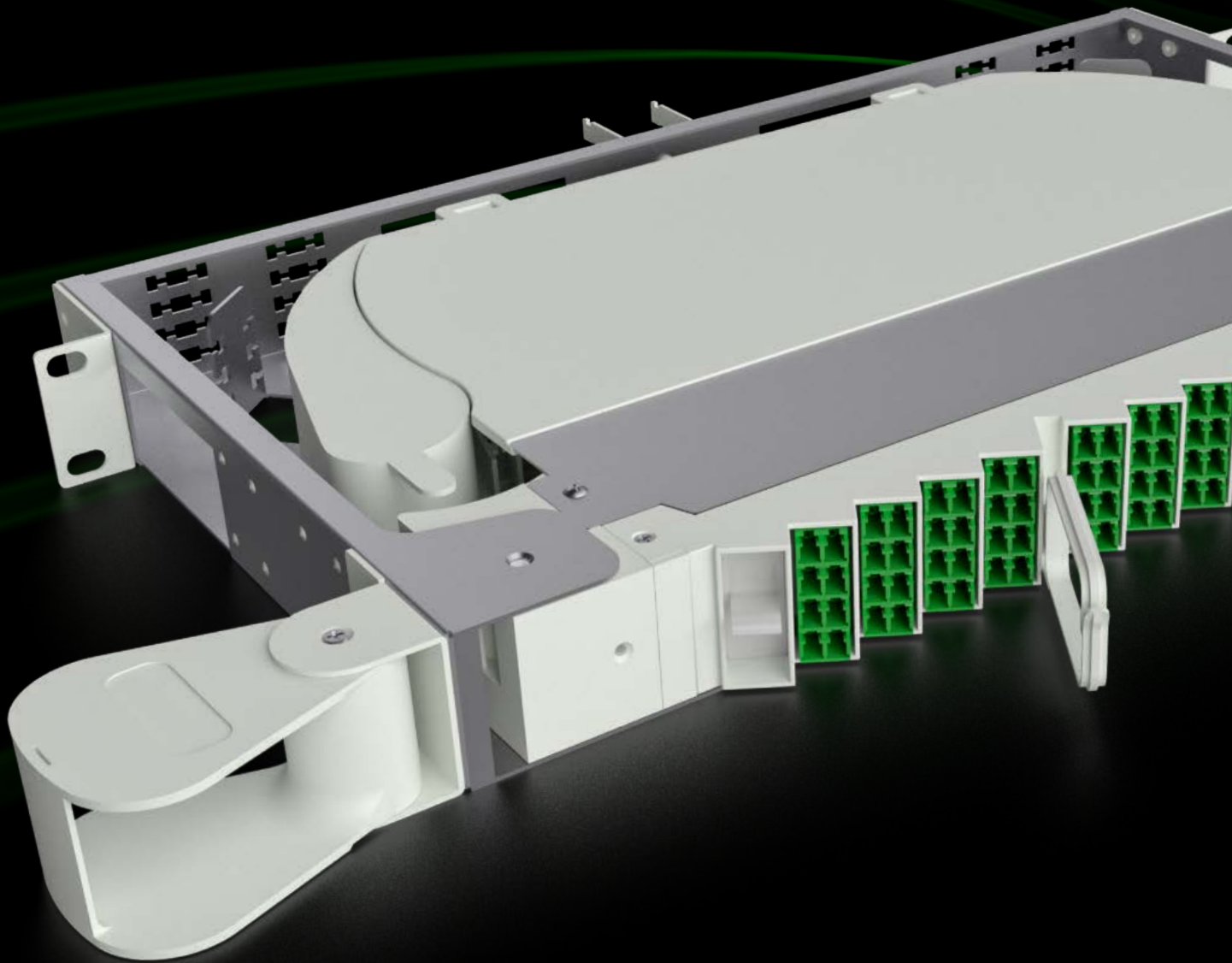

Encasa Pivot Panel

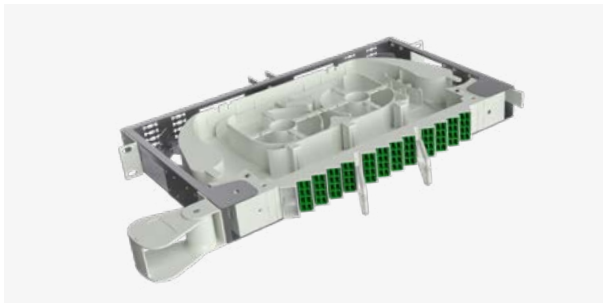

1U PIVOT PANEL



PRODUCT OVERVIEW

The Excel Encasa range of pivot panels have been designed to provide easy access when installing fibre into the network. These panels can be mounted within 19", 21" or 23" profiles within cabinets or street furniture, with options of Left / Right hand pivot points.

Available in 1U, 2U, 3U and 4U, each size has the option to have a front hinged door that offers extra protection for exiting patch cords and increases the available areas for labelling.

The panels come as standard with 48 adaptor positions allowing 96 fibres when using LC and 48 fibres with SC simplex per 1U.

The front adaptor plate can also be changed to offer lower fibre counts on request. Each panel is equipped with integrated fibre management to protect the fibre, with dedicated channels for the fibre to be routed to each splice tray, with each splice tray holding 24 splices per tray. Furthermore, this panel can be adapted to house crimp style splice protectors.

The fibre management trays can also be replaced to house ribbon fibre or 1:8, 1:16 and 1:32 splitters.

PRODUCT FEATURES



Adaptor Field



Cable Management - Front

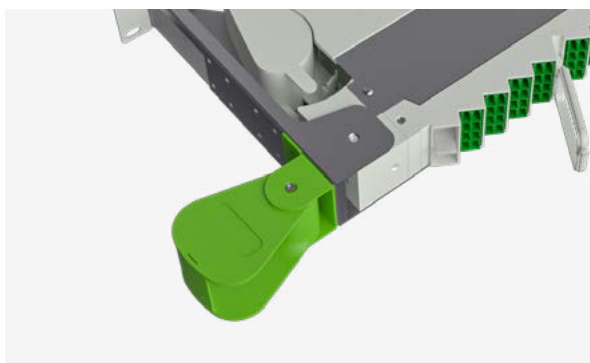

Cable Management - Side



Cable Management - Back

GENERAL

Maximum number of fibres	48 SC or 96 LC
Maximum number of splices	96
Adaptor Type	SC Simplex /LC Duplex
Maximum number of adaptor positions	48
IP rating	No
UV stable	No
Material	ABS+PC and Cold Rolled Steel
UL94-V0	Yes
Colour	Light grey (RAL 7035) or black (RAL 9005) Other colours available subject to MOQ
Dimensions (mm)	44mm H x 480mm W x 255mm D

SPLITTER OPTIONS

1:8 plc splitter	Maximum of 6
1:16 plc splitter	Maximum of 6
1:32 plc splitter	Maximum of 3

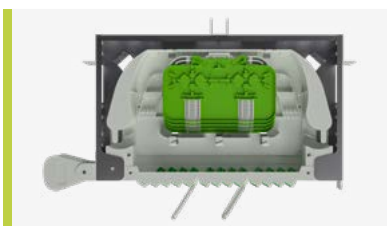

Splice Option - Splicing Tray

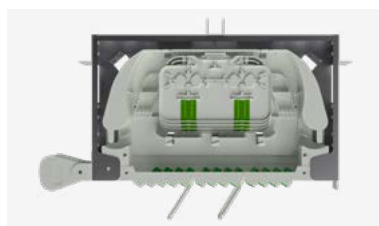

Splice Option - Splicing Area

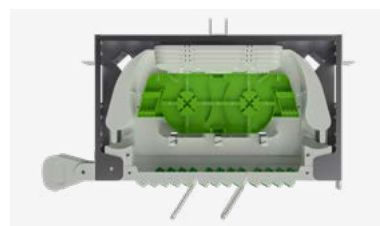

Splice Option - Cable Storage

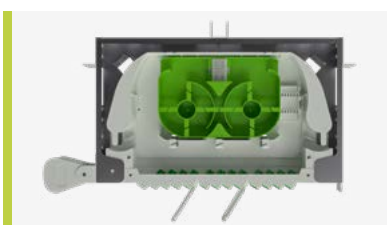

Splitter Option - Cable Storage

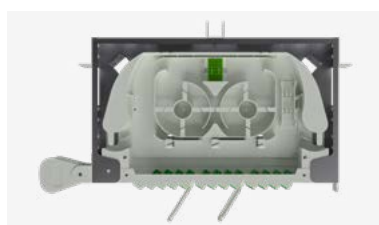

Splitter Option - Splicing Area

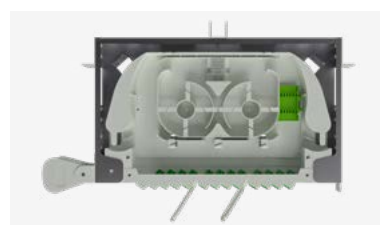

Splitter Option - Splitter Area 1:8



Splitter Option - Splitter Area 1:16

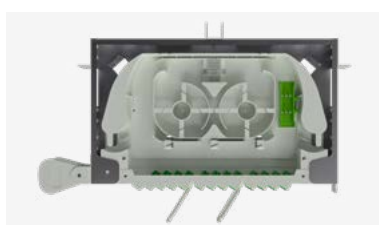

Splitter Option - Splitter Area 1:32

LC AND SC APC ADAPTOR SPECIFICATION

Insertion loss	< 0.2 dB
Durability (500 mating)	< 0.2 dB max increase
Operating temperature	-40°C to 80°C
Retention force	200 - 600 grams
Alignment sleeve material	Ceramic
Flammability rated	UL94-V0
Polish type	APC

SPLITTER SPECIFICATION

	1x4	1x8	1x16
Operating wavelength	1260 to 1650 nm		
Fibre type	G657A2		
Temperature stability (dB) at -40°C to 85°C	≤0.4	≤0.5	≤0.5
Storage temperature	-40°C to 85°C		
Return loss	≥55dB		

DIMENSIONS

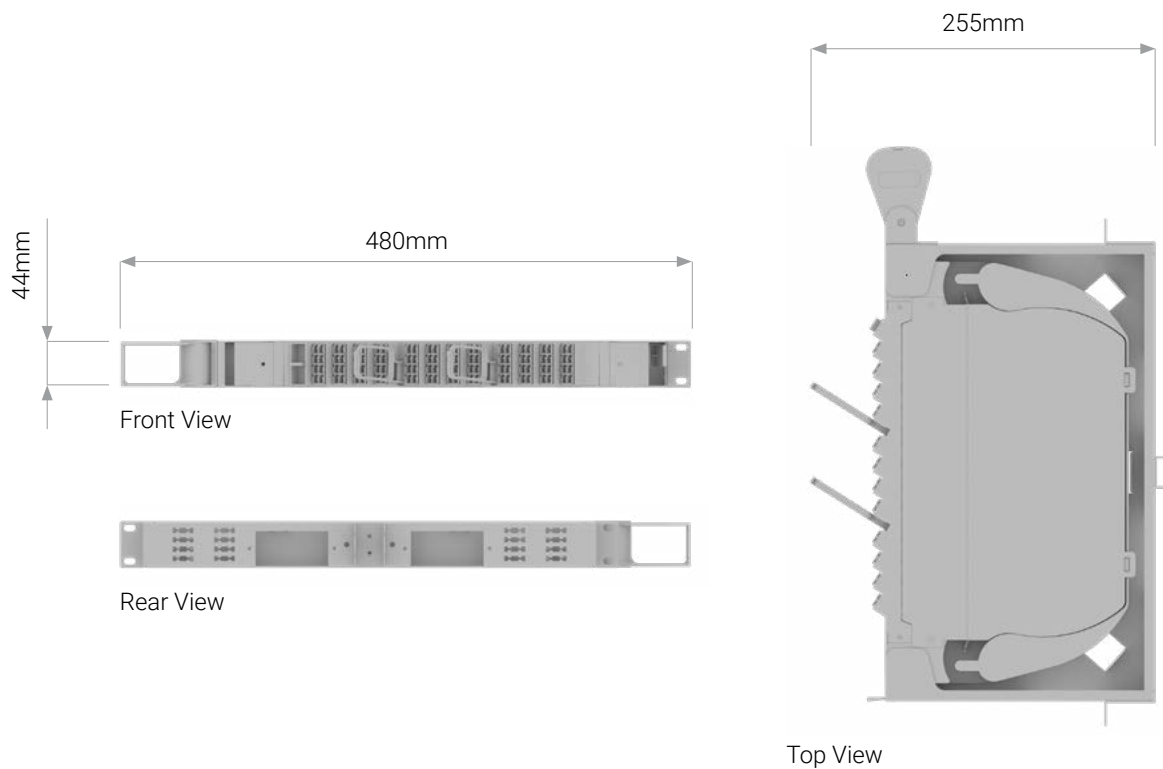

PART NUMBER INFORMATION

Part Number	Product Description
997-001	Encasa 24F 1U Pivot Panel with 24 SCA +24 Pigtailes Right-hand Pivot
997-002	Encasa 48F 1U Pivot Panel with 48 SCA +48 Pigtailes Right-hand Pivot
997-003	Encasa 96F 1U Pivot Panel with 96 LCA +96 Pigtailes Right-hand Pivot

Contact the Sales Team for information on the 2U, 3U and 4U Pivot Panel options available.

OTHER CONFIGURATIONS

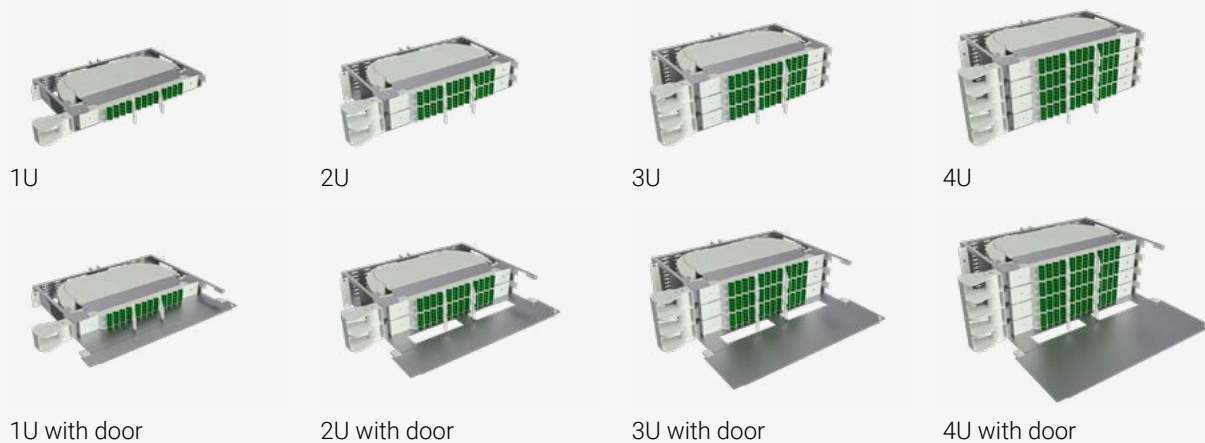



Excel House, Junction Six Industrial Park
Electric Avenue, Birmingham, B6 7JJ

Phone: 0800 75 75 65
Email: FTTx@mayflex.com

www.excel-networking.com

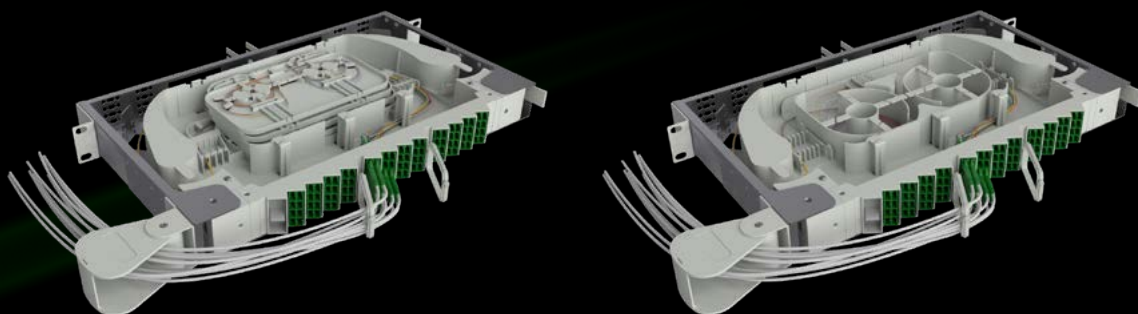

The Encasa range from Excel provides flexible, easy to use enclosures with a range of connection options and capacities, complemented by fast to install pre-connectorised cables.